



Moving Forward

BATTERY TECHNICAL DATASHEET

DIN100

PRODUCT SPECIFICATIONS

Design Code: 6002074

Approval Date: 12.08.2018

TECHNICAL DRAWING OF DIN100

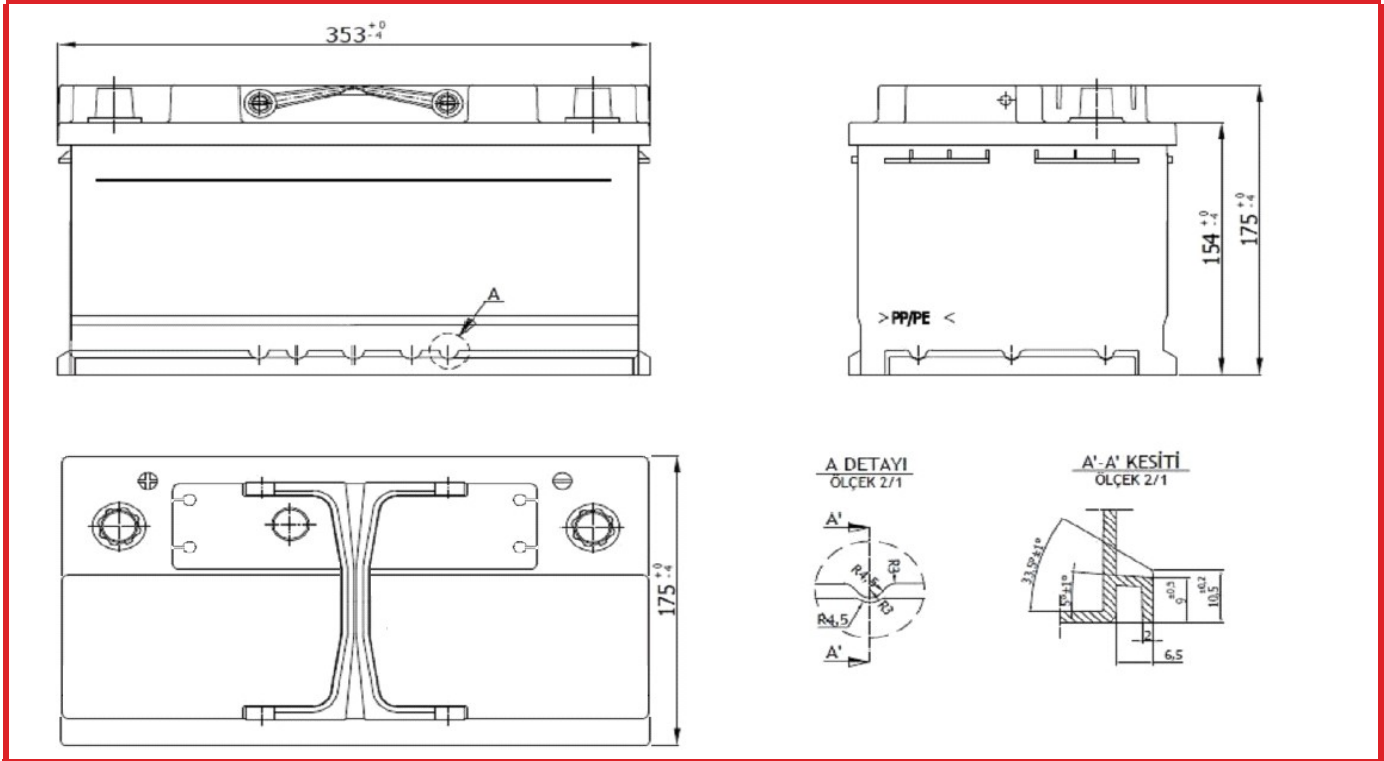

PRODUCT AND PHYSICAL SPECIFICATIONS

BCI GROUP CODE	MODEL NO.	VOLTAGE	CELLS	TERMINAL TYPE	DIMENSIONS			WEIGHT
					L	W	H	
93	DIN100	12	6	1	353	175	175	21.86kg ± 3%

ELECTRICAL SPECIFICATIONS

CRANKING PERFORMANCE			RESERVE CAPACITY (Minutes)	CAPACITY AMP HOURS(Ah)
CA @ 0°C	CCA @ 0°F	HCA @ 30°C	@ 25 AMPS	20-Hr
950	880	980	165	100

PRODUCT AND PHYSICAL SPECIFICATIONS

BOX TYPE	BOX COLOUR	HOLD DOWN TYPE	LID TYPE	LID COLOUR	TERMINAL LAYOUT	INDICATOR
L5B	BLACK	B13	SMF	BLACK	0	INCLUDED

PHYSICAL BATTERY SPECIFICATIONS DIAGRAMS

HOLD DOWN TYPE	TERMINAL LAYOUT	TERMINAL TYPE
<p>B13</p> <p>LIKE B3 WITH 5-NOTCHES</p>	<p>0</p>	<p>1 TAPERED TERMINAL IN COMPLIANCE WITH DIN 72311 T.4</p>